

Kossel Rev B Build Guide V1.0

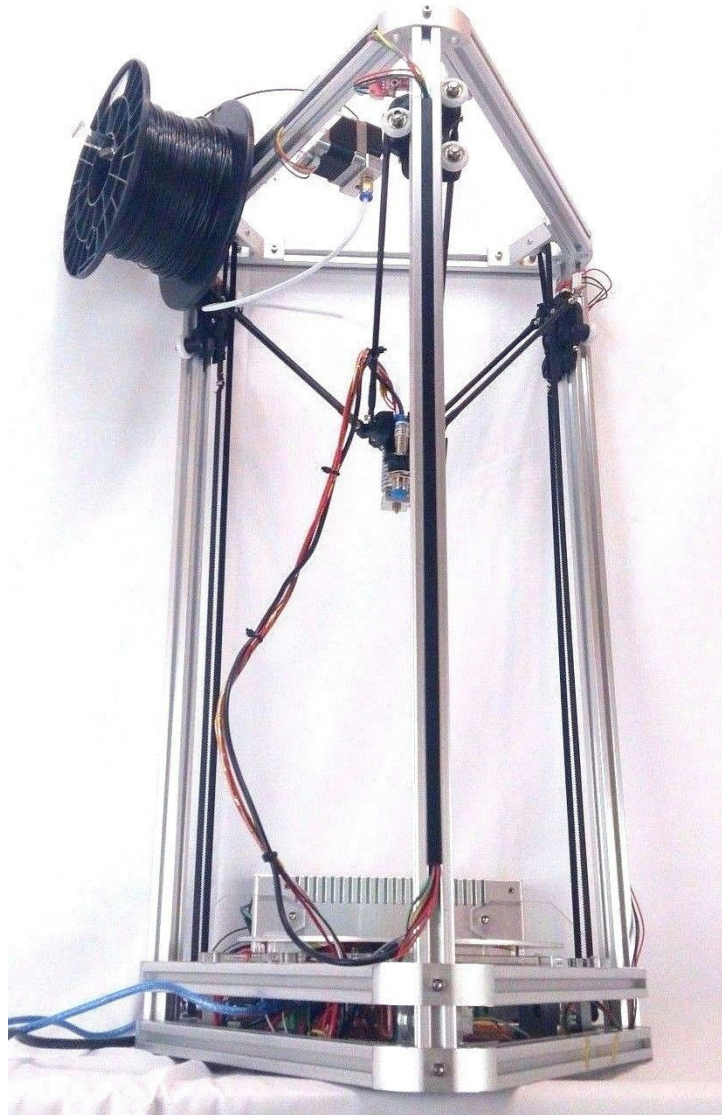

Table of Contents:

[Step 1: BASE ASSEMBLY](#)

[Gathering parts:](#)

[Building the Corners and Base:](#)

[Step 2: UPPER ASSEMBLY](#)

[Gathering Parts:](#)

[Building Upper:](#)

[Step 3: VERTICAL RAIL INSTALLATION](#)

[Gathering Parts:](#)

[Building Verticals:](#)

[Step 4: SLIDERS](#)

[Gathering Parts:](#)

[Building Sliders:](#)

[Step 5: CARRIAGE ASSEMBLY](#)

[Gathering Parts:](#)

[Building Carriages:](#)

[Step 6: DIAGONAL ROD ASSEMBLY](#)

[Gathering Parts:](#)

[Building Rods:](#)

[Step 7: END EFFECTOR ASSEMBLY](#)

[Gather Parts:](#)

[Building the End Effector:](#)

[Step 8: ATTACHING THE DIAGONAL RODS](#)

[Gathering Parts:](#)

[Attaching the Rods:](#)

[Step 9: ELECTRONICS ASSEMBLY](#)

[Gathering Parts:](#)

[Building the RAMPS Set:](#)

[Step 10: MOUNTING THE CONTROLLER](#)

[Gathering Parts:](#)

[Mounting the controller :](#)

[Step 11: ATTACHING TO FRAME](#)

[Gathering Parts:](#)

[Attaching Electronics:](#)

[Step 10: BOWDEN EXTRUDER ASSEMBLY](#)

[Gathering Parts:](#)

[Building the Extruder:](#)

[Step 10: HEATED BED](#)

[Gathering Parts:](#)
[Wiring the Heated Bed:](#)
[Step 10: Top Assembly](#)
[Gathering Parts:](#)
[Assembly:](#)
[Step 11: BELTS](#)
[Gather Parts:](#)
[Installing the belt:](#)
[Step 12: WIRING](#)
[Gathering Parts:](#)
[Notes and Hints:](#)

DISCLAIMER OF LIABILITY: FOLGER TECHNOLOGIES LLC specifically DISCLAIMS LIABILITY FOR INCIDENTAL OR CONSEQUENTIAL DAMAGES and assumes no responsibility or liability for any loss or damage suffered by any person as a result of the use or misuse of any of the information or product. FOLGER TECHNOLOGIES LLC assumes or undertakes NO LIABILITY for any loss or damage suffered as a result of the use, misuse or reliance on the information and or product.
USE AT YOUR OWN RISK: Never leave your printer unattended. This kit involves working with 110v/220v and should only be done if you are qualified, if you are not speak to a qualified electrician.

Step 1: BASE ASSEMBLY

Gathering parts:

6 – Aluminum corners for motors

6- 300mm 2020 Beams

12 - M3x8mm Bolts

36 - M4 2020 T-Nuts

36 – M4x10mm Bolts

3 – 2600g/cm Small Motors

3 - 20 Tooth GT2 Pulleys

Building the Corners and Base:

1. Place the GT2 Pulley on the motor and tighten the set screw, install the pulley as pictured with the set screw closest to the motor.
2. Attach the corners to the motors using the M3x8mm bolts (Make sure your motor connector is pointing to the side not up or down.)

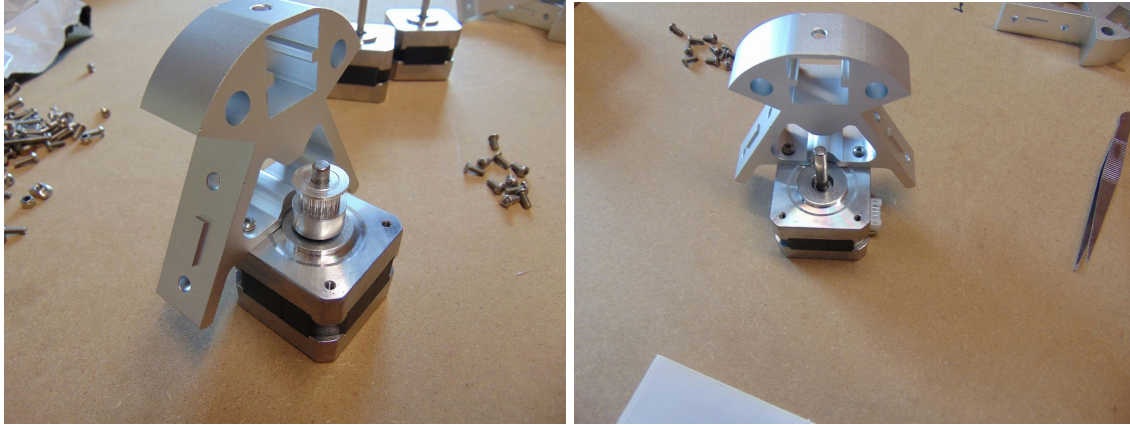

3. Using M4 T-Nuts and M4x10mm Bolts insert them through the side holes of you corner brackets as pictured. These will be used to secure the 2020 beam to the corners.

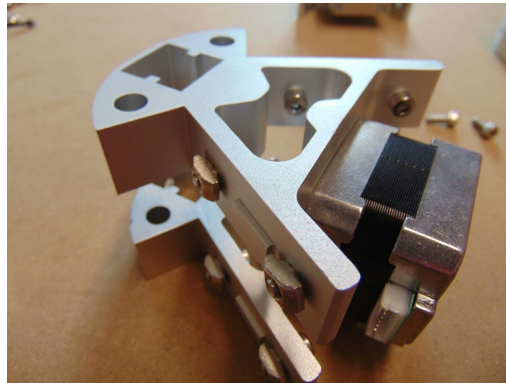

4. Attach 2x 300mm 2020 Beams to the right side of each corner as pictured below. Make sure the T-Nuts are loose enough to spin and lock down when installing them.

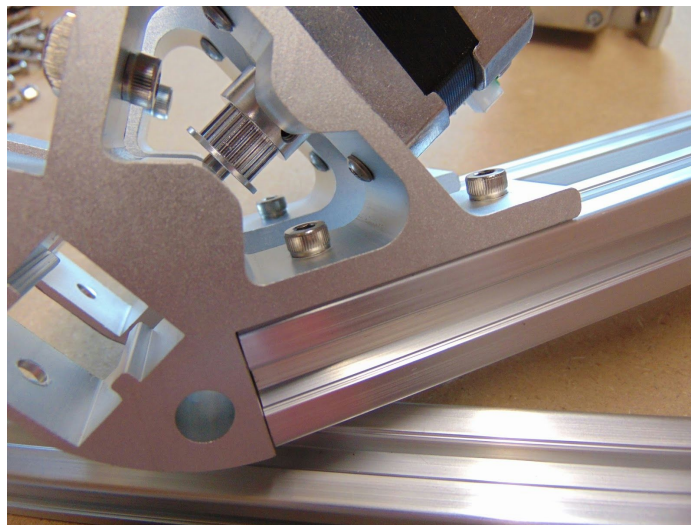

5. You can now combine the 3 sections as pictured. Tighten the T-Nuts and insure they twist and lock.

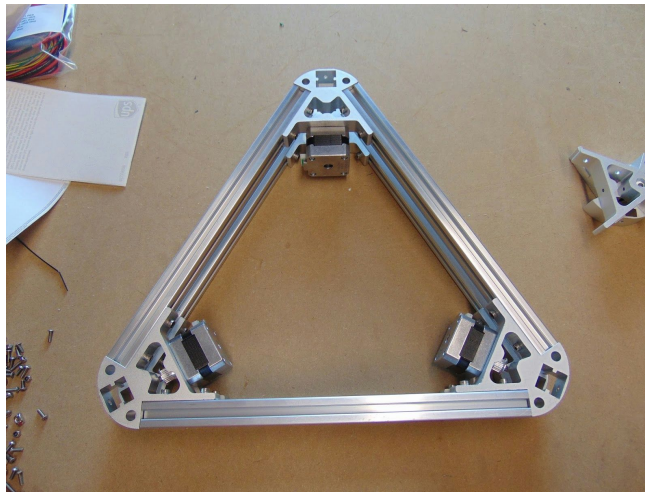
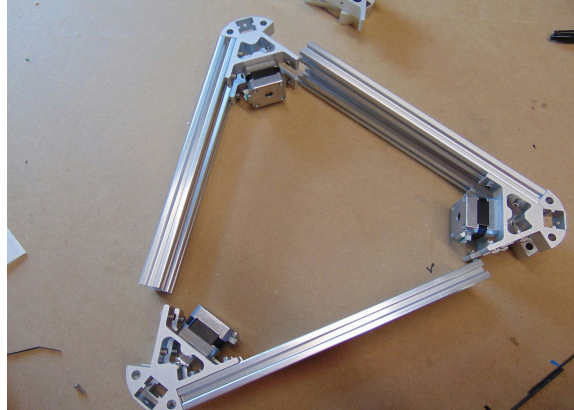

Base is now assembled giving a great platform to continue your build.

NOTE: Attach all beams before tightening or they may not line up properly.

Step 2: UPPER ASSEMBLY

Gathering Parts:

- 3 – Aluminum Corners for Tops
- 3 – 300mm 2020 Beams
- 12- M4 T-Nuts

12 – M4x10mm Bolts

3 – M3 Nylock Nuts

3 – M3x25mm Bolts

6 – F623zz Bearings

Building Upper:

1. Install the M4x10mm Bolts and T-Nuts as pictured.

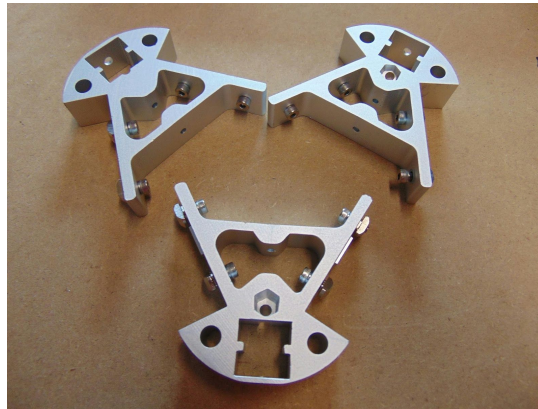

2. Install one 300mm 2020 Beam on left side of each corner in the same way they were done on the lower corners. Insure the all the corners are facing up when attaching, the up direction can be determined by the hex nut hole cut on one side.

3. Combine the 3 sections and tighten down the T-Nuts, insure they twist and lock.

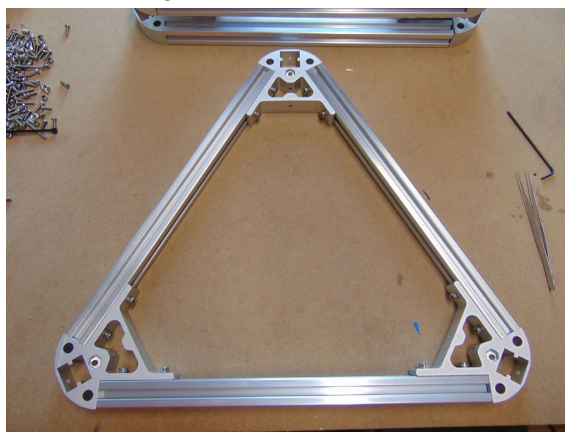

4. Next gather the 3 M3x25mm Bolts, 2 F623 Bearings, and 3 Nylock Nuts. Insert the bolt in the hole in the center point of the corners. Using a pair of plyers or a wrench thread the nylock nut partly onto the end of the M3 bolt that is coming through the back side of the corner so that you have a small amount of thread sticking out.

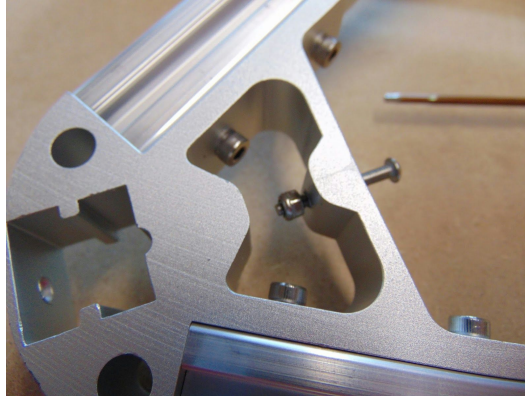

5. Using the two F623zz bearings face to face with the flanged side away from each other fit them onto the screw end allowing the screw to pass through them and continue into the other side of the corner as pictured.

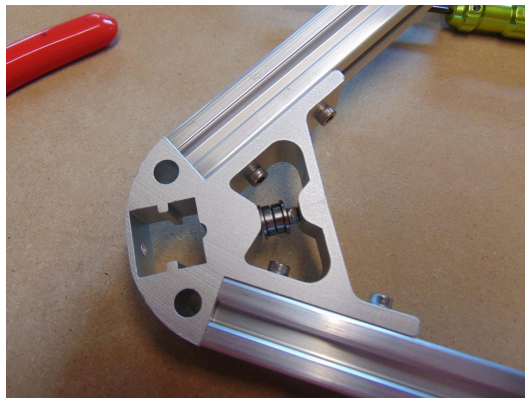
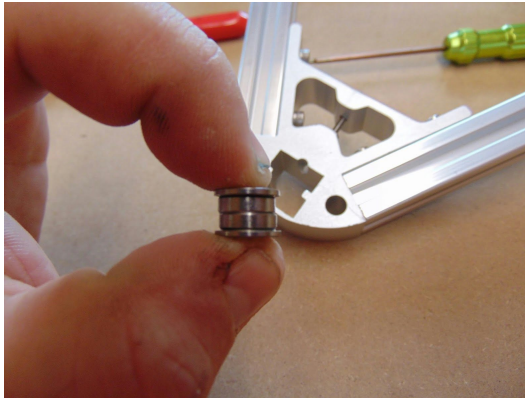

Step 3: VERTICAL RAIL INSTALLATION

Gathering Parts:

Gather the following parts:

3- 700mm 2020 Beams

9- M4x8mm Bolts

9- M4 T-Nuts

Building Verticals:

1. Start by putting the M4x8mm bolt through the outer center hole. Thread it into a M4 T-Nut placed on the inside of the corner piece. Repeat the process for all 8 remaining corner pieces.

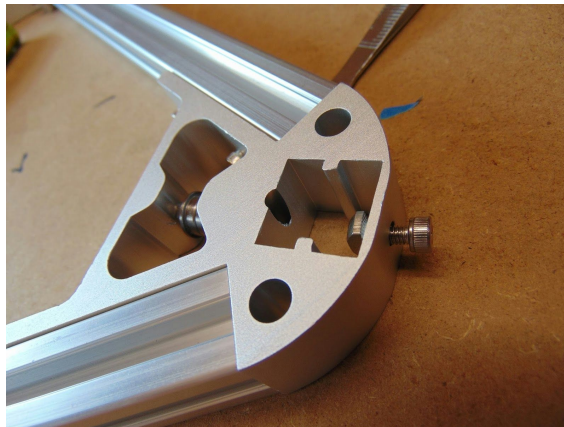

2. Once all the bolts are in place insert the 700mm 2020 Beams into the base assembly. Lock them in place securely using the bolt and T-Nut.



Step 4: SLIDERS

We are now going to assemble some of the smaller parts of the kit. Remember we are dealing with plastic printed parts and some clean up may be needed to ensure parts fit properly.

Gathering Parts:

- 3- Printed Slider Carriages
- 9- Roller Wheels
- 9- M5X25mm Countersunk Bolts
- 9- M5 Nylock Nuts
- 3- M3x20mm Bolts
- 3- M3 Nuts



Building Sliders:

1. Screw the M5x25mm bolts into the back of the slider bracket as pictured.

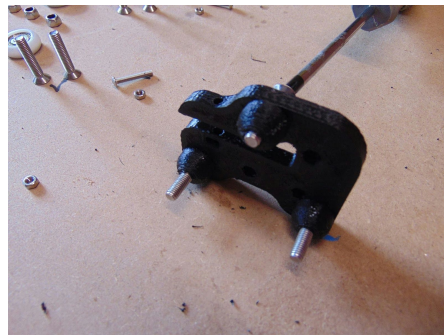

2. Once the bolts are in place, put the wheels on to the end of each M5 bolt, then secure in place using the the M5 Nylock Nut (It is a good idea to not tighten down on the nut too much as it may impede motion of the roller).

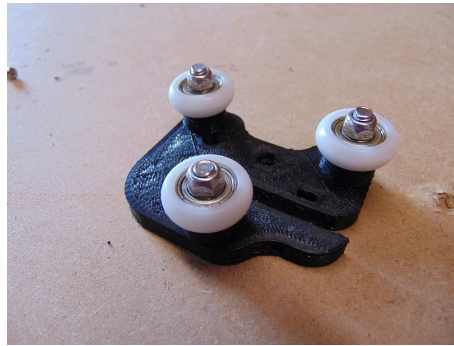

3. Insert the M3x20mm bolt through the side hole on the slider bracket and place the M3 Nut in the slotted opening in line with bolt and thread them together slightly. (This is the tensioner for the sliders that will be adjusted later.)

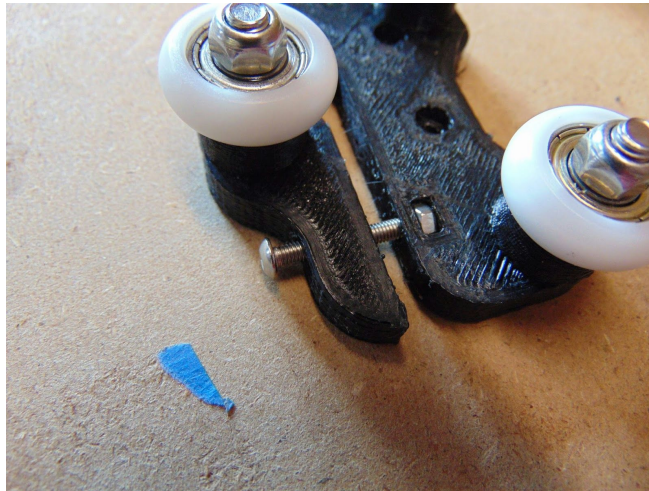

4. Repeat these steps for all three sliders.

Step 5: CARRIAGE ASSEMBLY

Gathering Parts:

Gather the following parts:

3- Slider Assemblies (Assembled in step 4)

3- Belt Carriages

6- M3x20mm Bolt

3- M3x16mm Bolt

9- M3 Nuts

Building Carriages:

1. Insert the 3 M3 Nuts into the recesses on the slider assembly. They should fit snugly.

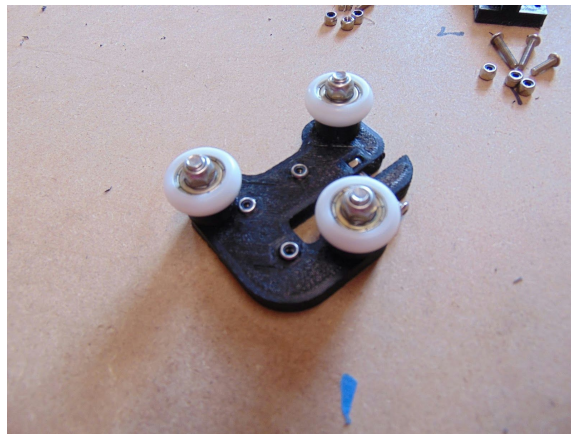

2. Insert 2 M3x20mm Bolts into the upper part of the carriage. Insert 1 M3x16mm Bolt into the lower part of the carriage



3. Line up the Belt Carriage with the Slider Assembly so the bolts line up with the bolt holes. You can now attach the carriage to the slider as pictured

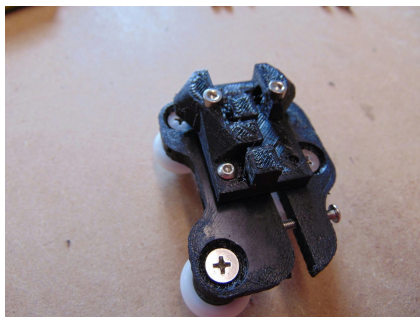

Step 6: DIAGONAL ROD ASSEMBLY

Gathering Parts:

3- Carbon Fiber Rods

1- M3 Threaded Rod

12- Tie Rod Ends

Hacksaw blade

Long aluminum extrusion

1- M3x8mm Bolt

1- M3 T-Nut

Building Rods:

Using the hacksaw blade, measure and cut the threaded rod into 12x 30mm sections, screw them half way into the Ball Links.



Measure the distance (in mm) from the end of the ball link to the center of the bolt hole and write it below.



Calculate your rod length:

Target total Length of diagonal rod 240 mm

Subtract ball link measurement-_____ x2= _____ mm

Subtract multiplied ball link value from total length to get cut rod length _____mm

The ball links used when this manual was written have a measurement of 25cm from the end to the bolt hole. We took this value, multiplied by 2 (for both ends) and subtracted from our target rod length of 240mm.

Using the aluminum extrusion, M3x8mm Bolt and M3 T-Nut, make a cutting jig as shown:

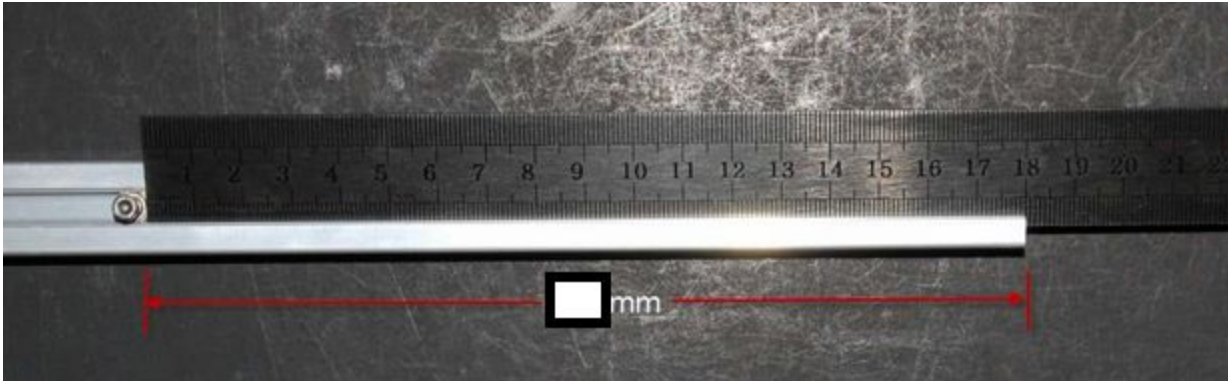

Using the jig and the hacksaw blade, cut the carbon fiber rods into the 6 equal length rods. Use light pressure while cutting, this will reduce the chance of splintering.



Take all 6 rods and 12 ends and line them all up using the 2 long M3 screws and T-Nuts, make sure the ends are all aligned perpendicular to the screws. Make sure both sides are aligned the same way.

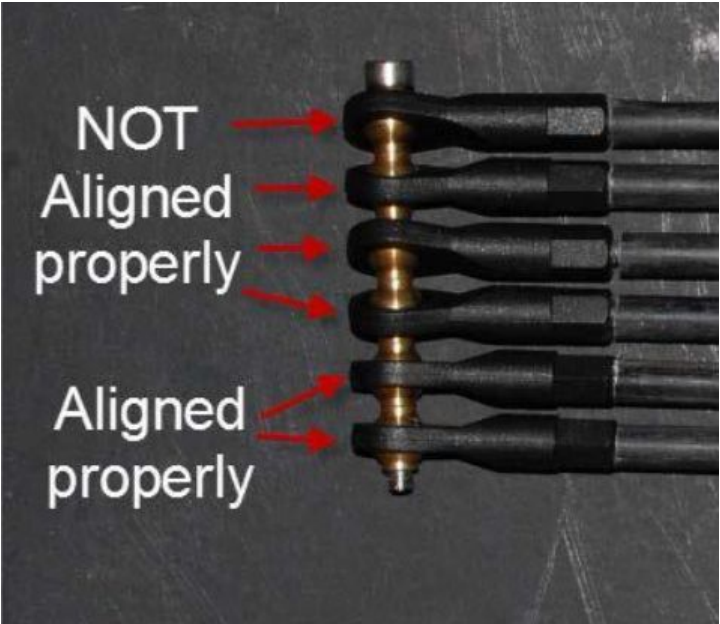

Apply the supplied glue to the threads and push the rods together ensuring that they are all aligned properly and straight on BOTH sides. Set the rods aside for now to let the glue dry.

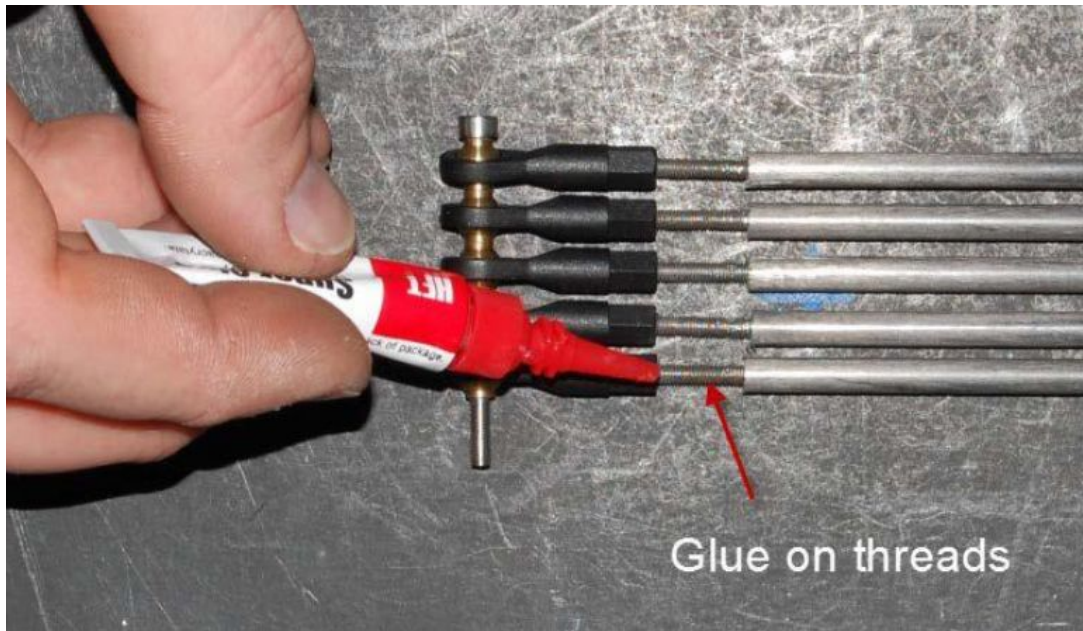

Step 7: END EFFECTOR ASSEMBLY

Gather Parts:

GATHER THE BOWDEN EXTRUDER SUB KIT:

- 1- Roll Kapton tape
- 4- M3x25mm Bolts
- 4- M3 Nylock nuts
- 1- 1.75mm Bowden All Metal Hot end
- 1- Cooling Fan
- 1- Inductive Sensor Probe
- 1- Hot End/Sensor Mount

1- End Effector Plate

2- M3x12mm Bolts

Building the End Effector:

1. Dry fit your parts. The Hot End/Sensor Mount might need to be sanded to allow the hot end to fit. It should fit tightly in the slot.

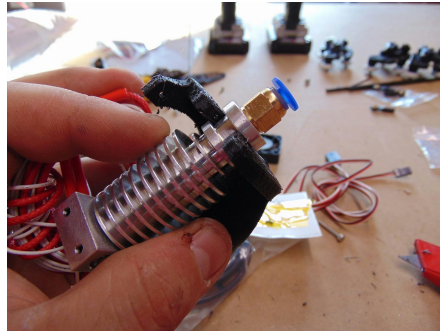

2. Once the hot end fits tightly into the mount we are going to attach the hot end to the End Effector using 4 M3x25mm bolts and 4 M3 Nylock Nuts.

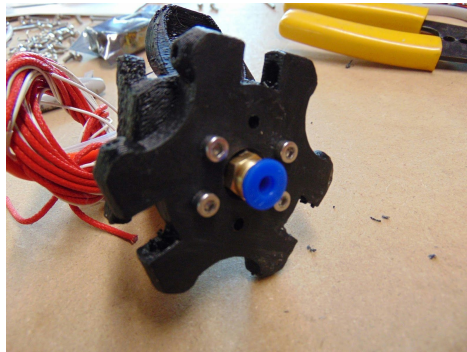

3. Once the hot end is attached we can now attach the inductive sensor. Make sure it fits before forcing it in, some sanding may be necessary.

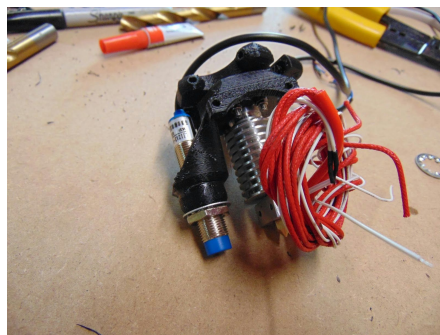

4. The probe should be mounted almost level with the print head using the 2 Jam Nuts supplied with the probe. Make sure the washers are sitting below the mount.

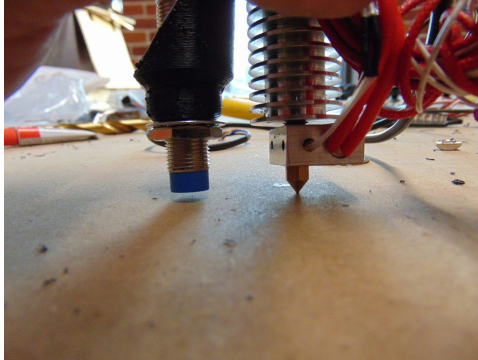

5. Using 2 M3x12 bolts, mount the Cooling Fan to the Hot End mount so the wires are at the top. The effector is complete, we now need to attach the diagonal rods.

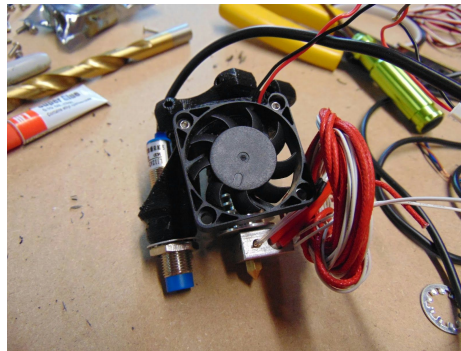

Step 8: ATTACHING THE DIAGONAL RODS

Gathering Parts:

- 6- Tie Rods (Assembled in step 6, make sure the glue has had enough time to dry)
- 12-M3x25mm Bolts
- 12-M3 Nylock Nuts
- 3- Carriages (Assembled in Step 5)

Attaching the Rods:

Attach the tie rod ends to the tapered side of the effector using 1 M3x25mm bolt, and 1 M3 nylock nut for each rod. NOTE: The nylock nut fits into a recess on the printed part.



Now we are going to attach the 3 Carriages to the tie rods in the same manor to make one center assembly.

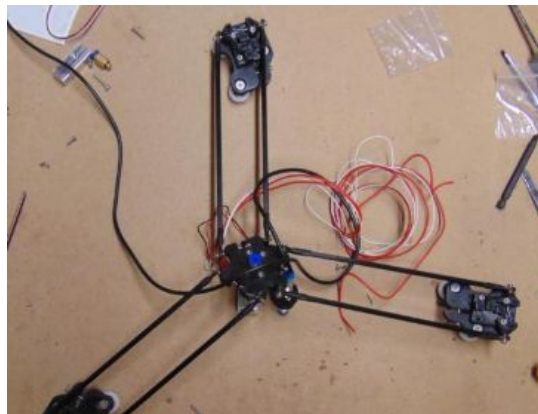

Step 9: ELECTRONICS ASSEMBLY

Gathering Parts:

1- RAMPS/MEGA/STEPPER DRIVERS

Building the RAMPS Set:

This is the “brain” of the printer and is composed of an Arduino Mega 2560 Board (programmable controller), a RAMPS 1.4 Shield (provides all the necessary connections for the motors, sensors, hot end and heated bed) and the A4988 Stepper Drivers that control the power and signals to the stepper motors.

NOTE: Some RAMPS sets come prebuilt and these steps are not needed. If your Board is pre-assembled, move to Step 10.

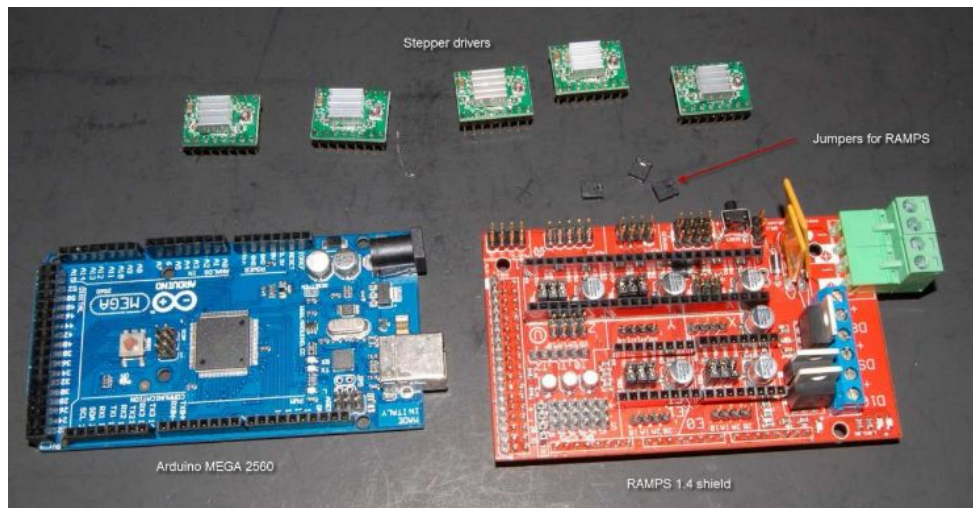

Install ALL the jumpers on to the RAMPS board as shown:

This enables 1/16th microstepping for the stepper drivers, which is where the precision is derived from.

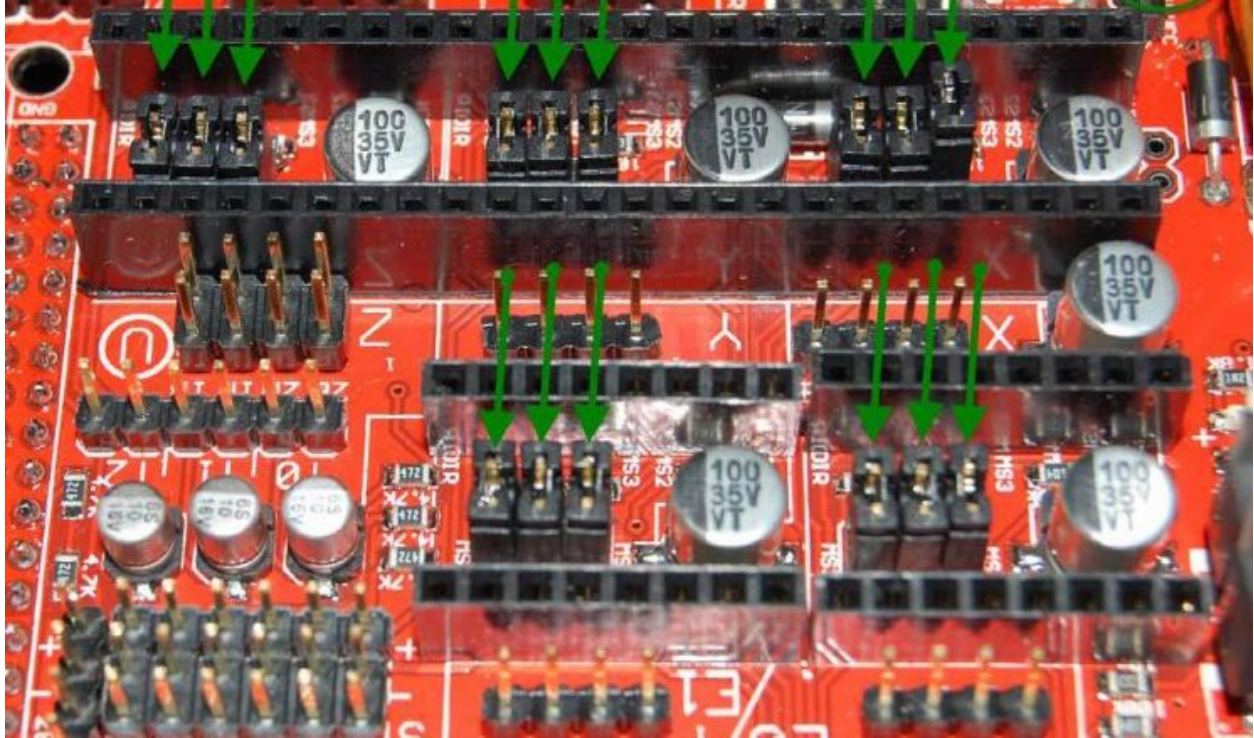

If your stepper drivers have heat sinks, peel the tape off of the back and apply the heat sink to the chip on the drivers. Align the stepper drivers as shown with the small potentiometer towards the top of the board and press them down on to the board



Align the pins and sandwich Ramps and Mega Boards, be sure they are tight and secure.



Step 10: MOUNTING THE CONTROLLER

Gathering Parts:

Laser Cut Mounting Sub Kit

2- M3x30mm Bolts

2- M3 Nylock Nuts

4- M3x12mm Bolts

4- M3 T-Nuts

Mounting the controller :

Mount Ramps and mega to the larger acrylic bed mount using 2 M3x30mm Bolts and 2 M3 Nylock Nuts. Use the 2 circular spacers so that the boards can sit a little more level.

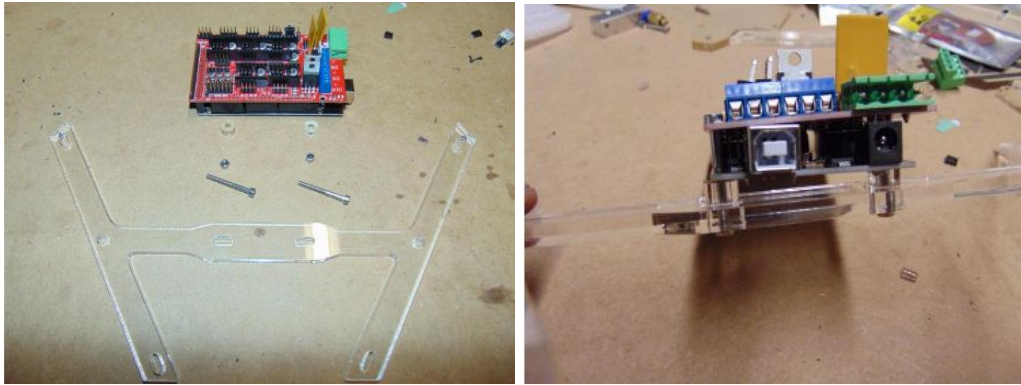

Once the ramps and mega are secure, prep the mount for installation into the frame by putting 4 M3x12mm Bolts into the corners of the mounting frame and securing them with M3 T-Nuts. Make sure your boards are facing downward.

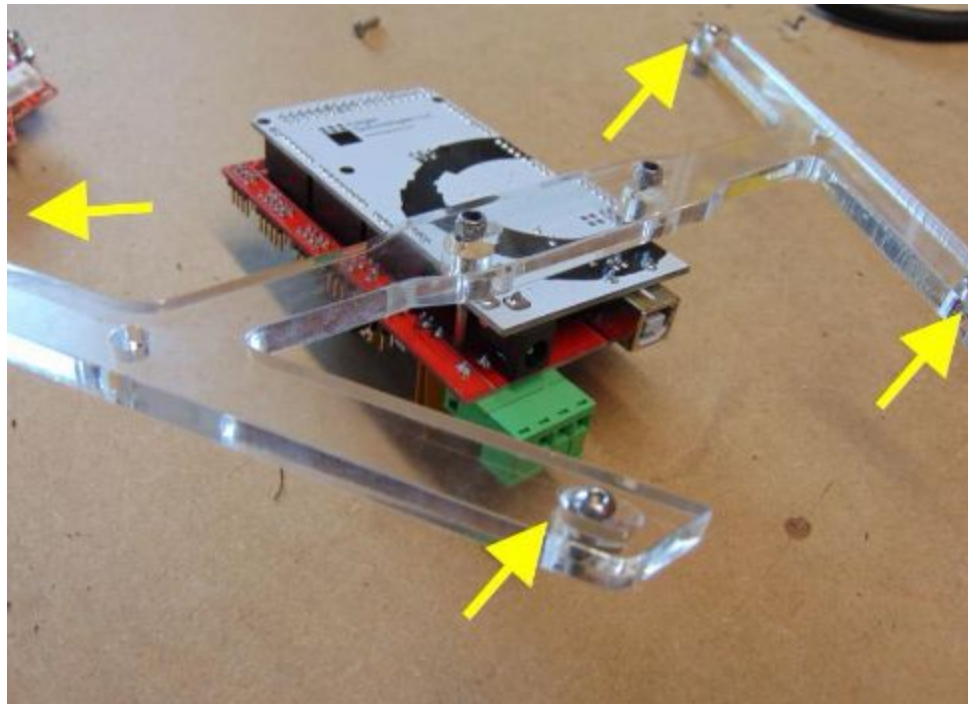

Step 11: ATTACHING TO FRAME

Gathering Parts:

- 3- End Stops
- 3- Laser Cut End Stops Mounts(Pictured in Sub Step 1)
- 13- M3x12mm Bolts
- 6- M3 Nylock Nuts
- 10- M3 T-Nuts
- 2- M4x10mm Bolts
- 1- Controller Mount (Assembled in Step 10)
- 1- Bed Support (Pictured in Sub Step 2)
- 2- Laser Cut Power Supply Mounts(Pictured in Sub Step 4)

Attaching Electronics:

1. Mount endstops to the endstop holders. Using 2 M3x12 Bolt and 1 M3 nylock nuts. Make sure that the switch is in-line with the hole in which we are going to attach it to the printer. We are also going to prepare these for mounting by insert an M3x12 bolt through the mounting hole and securing it with 2x M3 T-Nut.

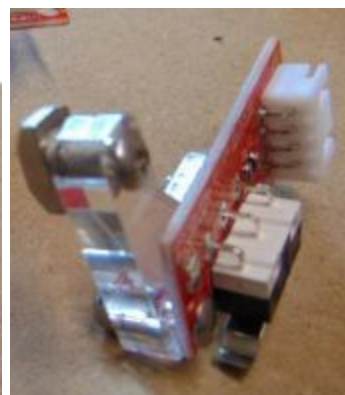

2. Attach the Controller Mount to the frame so the smaller length sits toward the flat side of the frame. Using 2 M3x12mm Bolts and 2 M3 T-Nuts attach the Bed Support as pictured.

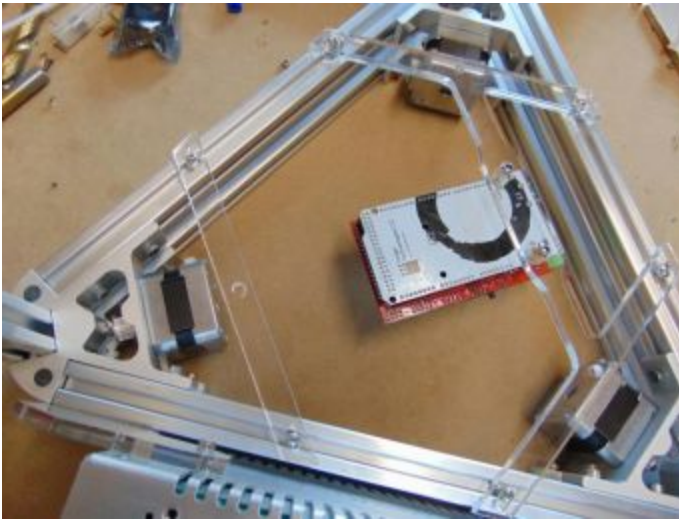

3. Mount the power supply to the left side of the frame using the supplied mounting brackets (pictured below). Use the M4x10mm Bolts to mount the Power supply to the brackets, use the M3x12mm Bolts and the M3 T-Nuts on the remaining holes as pictured.

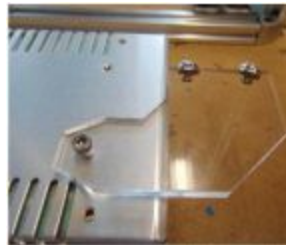
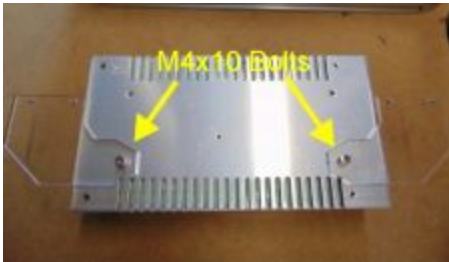

Step 10: BOWDEN EXTRUDER ASSEMBLY

Gathering Parts:

- 1- 4800g/cm Large Motor
- 1- Spring Loaded Injection Molded MK9
- 2- M3x45mm Bolts

- 1- Upper Aluminum Extruder Block
- 1- Push Fit (Brass fitting with blue plastic)
- 1- Laser Cut Mounting Plate (pictured in sub step 3)
- 2- M3x20mm Bolts

Building the Extruder:

1. Remove the 2 screws in the back of the motor opposite the wire connector location.

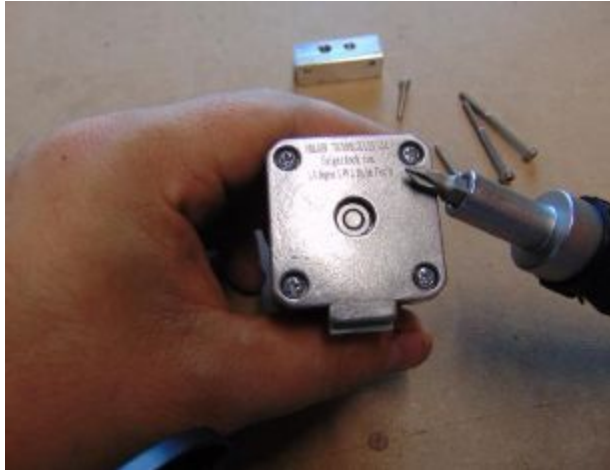

2. With the motor flat on the table and the connector facing you install the drive gear (with set screws sitting nearest the motor) and tighten the set screws on the drive gear to secure it to the motor shaft. Next install the Spring Loaded MK9, and Upper Aluminum Block in that order. Secure the Aluminum Block using 2 M3x20mm Bolts. Screw in the Push Fit as pictured below.

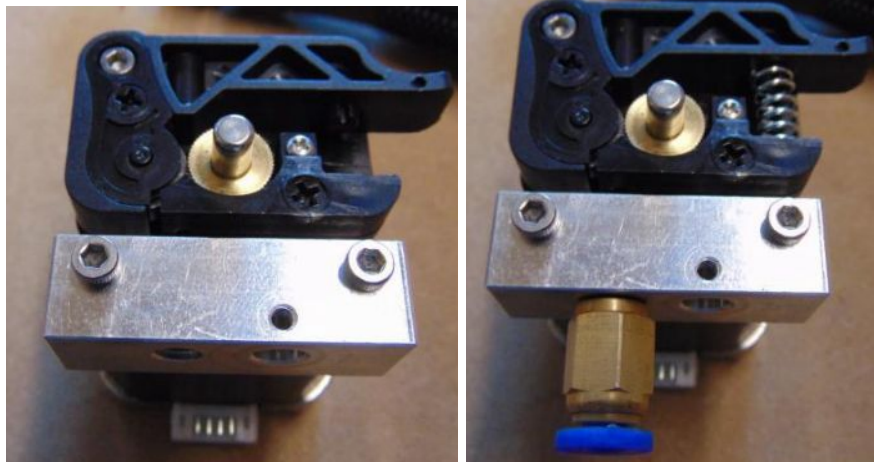

3. Mount the extruder to the mounting plate using the 2 M3x45mm Bolts.

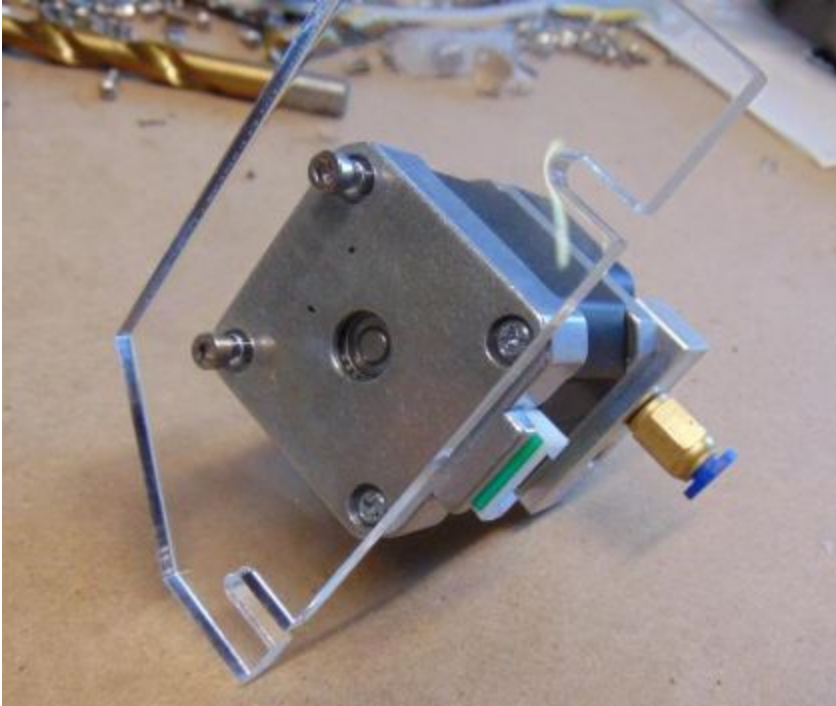

Step 10: HEATED BED

Gathering Parts:

1- Round Heat Bed

1- Thermistor

3- M3x16mm Bolts

3- M3 Nylock Nuts

Kapton Tape

Red 14AWG Wire

Black 14AWG Wire

Wiring the Heated Bed:

Cut 250mm section of both red and black 14AWG wire.

Strip both ends of each wire to prepare for soldering.



Solder one end of each wire to the two large solder pads on the printed side of the heat bed.



Once your solder joints are cooled off we are going to tape the end of the thermistor to the center of the printed side of the heat bed using Kapton Tape. The little glass ball is the temp sensor.



This completes the wiring for the heated bed

Step 10: Top Assembly

Gathering Parts:

- Pre-Made 'END EFFECTOR ASSEMBLY'
- Pre-Made 'UPPER ASSEMBLY'
- Pre-Made 'BOWDEN EXTRUDER ASSEMBLY'

2 - M3x8mm

2 - M3 T-Nut

Assembly:

To make this easier we left the top of the machine off

Slide our 'END EFFECTOR ASSEMBLY' right over the towers .

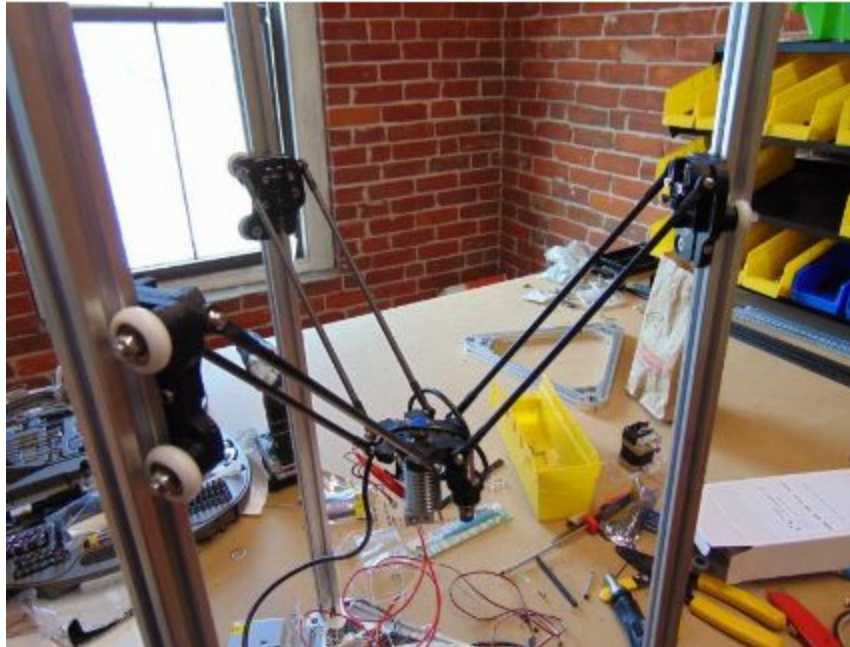

Slide the 'UPPER ASSEMBLY' on the top leaving about 20mm of the vertical 20mm beams sticking out.

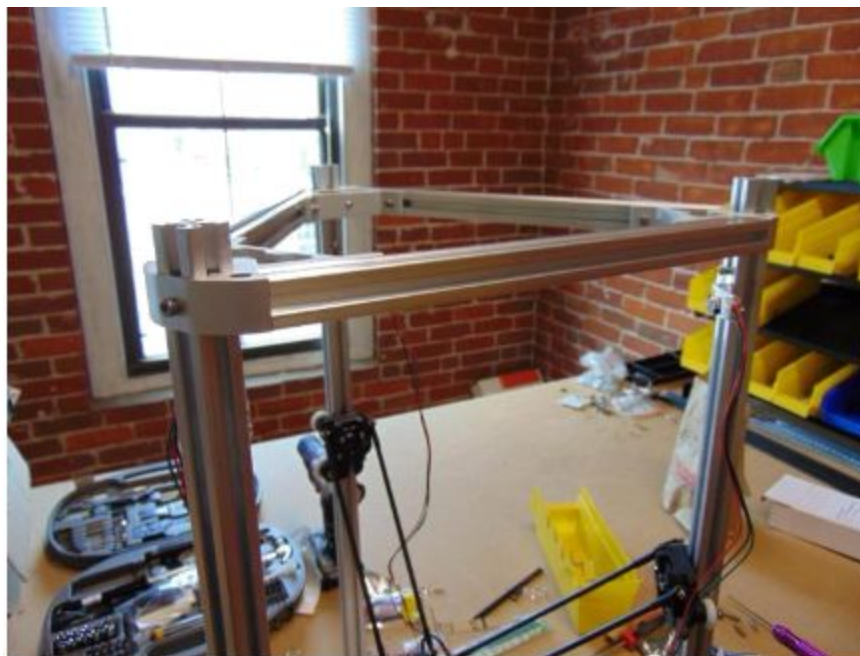

You can now install the endstops, making sure to place them an equal distance to the top of the beam. The distance you pick is not critical because this distance will be changed in the firmware during the configuration process.



3.) Use 2 M3x8mm bolts and 2 M3 T-Nuts to attach the extruder to the 'UPPER ASSEMBLY' of the printer.



Step 11: BELTS

Gather Parts:

- GT2 Belt
- 6x Zip Ties
- 3x Belt Springs

Installing the belt:

- Cut your Belt material Into 3 equal lengths roughly 1.6m.
- Feed the belt around your upper idler bearings and lower pulleys.

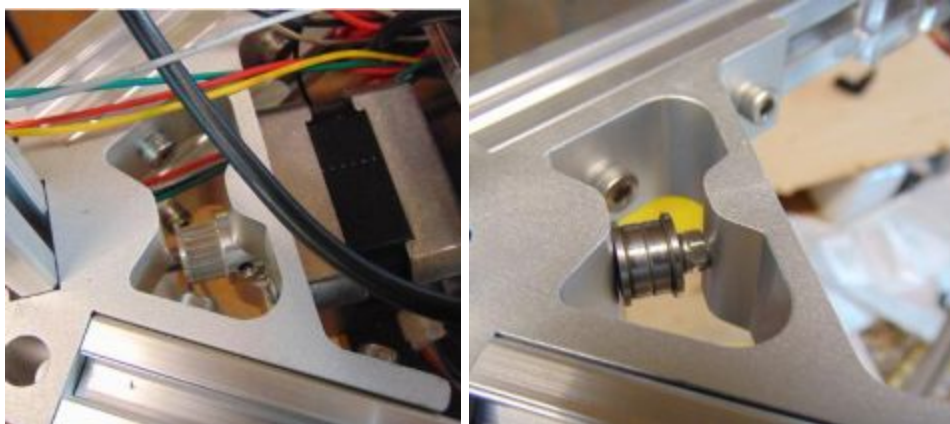

- Secure belt to carriage by creating a loop in the belt and holding the teeth side together with a zip tie. Leave the belts slightly loose.



This is a good time to install the belt tensioning springs.
Best place to install them is below your carriage just below the ziptied connection.



Next we are going to loosen the three bolts on the 'UPPER ASSEMBLY' of our printer that holds our top frame in place. We are then going to use that to tension the belts manually.

Step 12: WIRING

Gathering Parts:

- 3- End Stop Wires
- 4- Motor Wires (3 Short, 1 Long)
- 14AWG Wire (Black + Red)

- 28AWG Wire (Black + Red)
- Servo Wire (3pin 3 wires)
- 10k Resistor
- 15k Resistor
- Red and Black Pigtail (Extruder Thermistor Connector)
- AC cord

KOSSEL 2020 Rev B Wiring Diagram Rev 1.0 by LDR

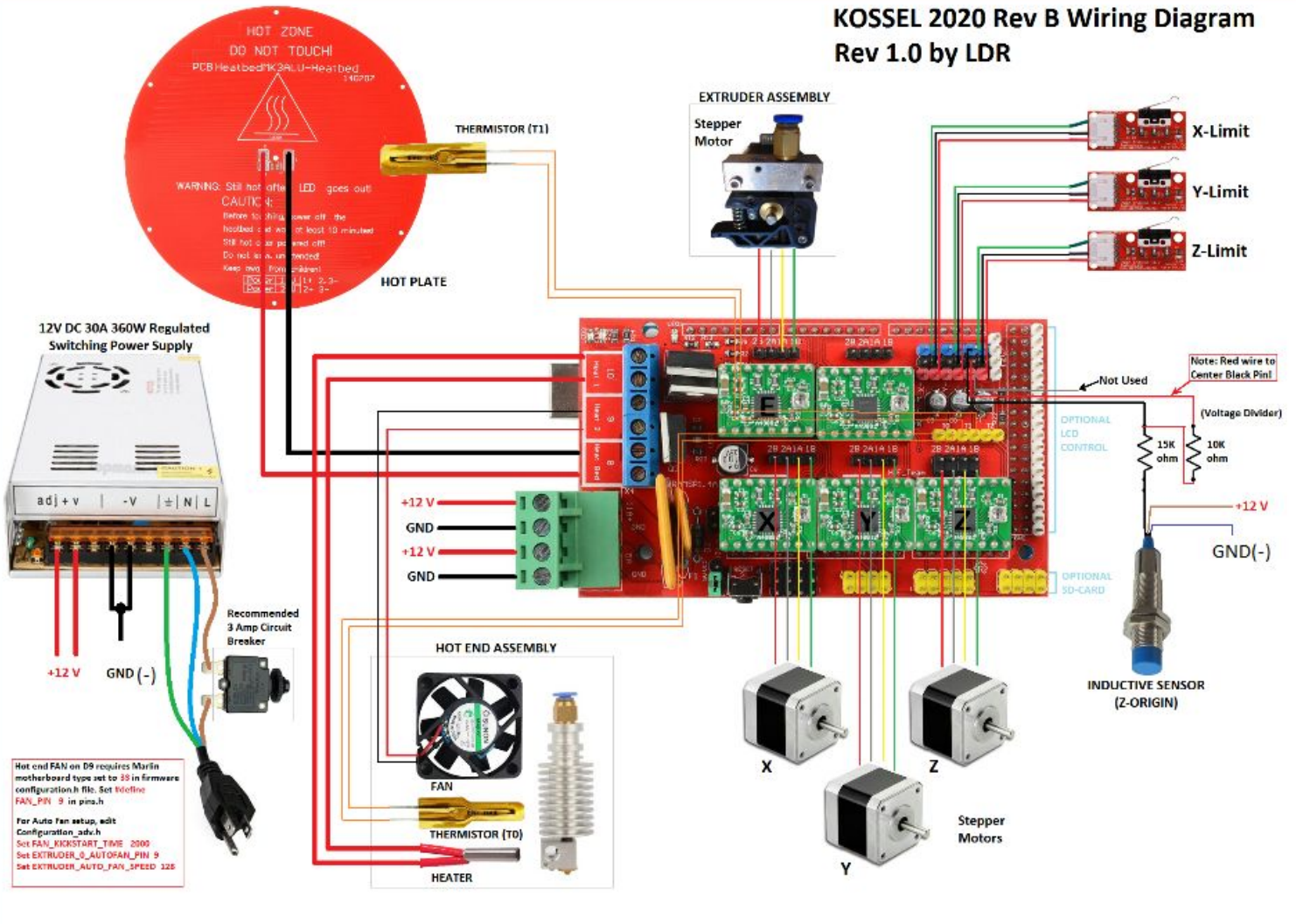

Notes and Hints:

Pig tail

Fan wire extension

Resistors

Endstops wire color placement crucial

Bed Thermistor - T1

Extruder Thermistor- T0

Z-height and offset values must be set